



Product manual

FDSD

Smoke control damper

Fire protection

Version 1.0.8
Issue Date: 01.07.2021



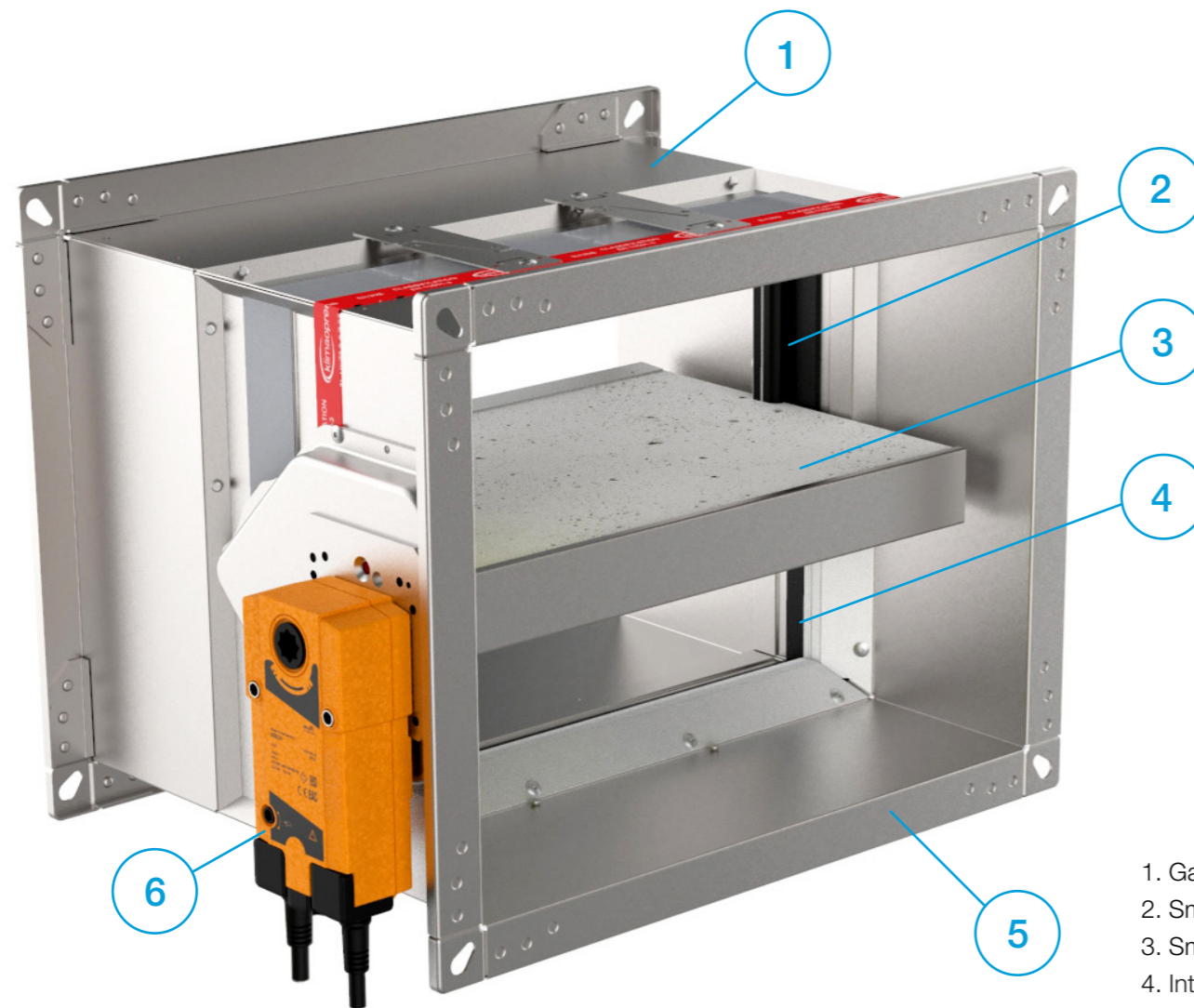

1. Galvanized steel sheet casing
2. Smoke seal
3. Smoke resistant damper blade
4. Intumescent joint
5. Connection flanges
6. Actuator

- ▼ [PRODUCT OVERVIEW](#)
- ▼ [DIMENSIONS](#)
- ▼ [INSTALLATIONS](#)
- ▼ [ACTUATORS](#)
- ▼ [COMMUNICATIONS MODULES](#)
- ▼ [REPLACEMENTS](#)
- ▼ [MAINTENANCE AND OPERATION](#)

SMOKE CONTROL DAMPERS

PRODUCT OVERVIEW

Smoke control dampers FDS D are used in smoke extraction systems for extraction of smoke gases or providing supply air to one or more fire compartments. Smoke control dampers consist of steel sheet case, calcium silicate damper blade, damper blade mechanism outside of the airflow and an electric actuator.

Smoke control damper case is made out of galvanized steel sheet casing. Variants produced from stainless steel and powder coated steel are also available. Calcium silicate blade is equipped with brass bearings and seals made out of polyurethane and elastomer rubber.

Smoke control dampers FDS D are produced in sizes from 200x200 till 1500x800 mm.

FDS D dampers are equipped with Belimo actuator drives in 24 V or 230 V versions.

Activation of smoke control dampers equipped with electric drives can be via smoke detector or remotely via control signal. Rearming of the electric smoke damper can also be done remotely via control signal. All electric actuators are equipped with end switches for position signalling.

In the case of fire, there are two possible safe positions for the smoke control damper, open or closed, depending on the situation on site and smoke extraction scenario.

Smoke control dampers are designed for installation in standard rigid supporting construction at least 100 mm thick, with bulk density of at least 450 kg/m³. For such installations, fire resistance up to 90 minutes is achieved.

All smoke control dampers are tested according to the EN 1751 for airtightness and retain class 3 leakage on the closed damper blade and class C on the casing air leakage.



- ▼ [PRODUCT OVERVIEW](#)
- ▼ [DIMENSIONS](#)
- ▼ [INSTALLATIONS](#)
- ▼ [ACTUATORS](#)
- ▼ [COMMUNICATIONS MODULES](#)
- ▼ [REPLACEMENTS](#)
- ▼ [MAINTENANCE AND OPERATION](#)



FIRE RESISTANCE CLASSIFICATION

FDSD fire resistance is tested according to EN 1366-10 "Fire resistance tests for service installations. Smoke control dampers" Classification of the smoke control dampers is defined according to EN 13501-4. Fire classification of construction products and building elements using data from fire resistance tests.

Installation in horizontal axis of rotation of the dampers blade is acceptable.

Fire resistance of smoke control damper depends on classification of walls. It is allowed to install products to walls only according to products Declaration of Performance.

Walls with greater fire resistance can also be used. Smoke damper should be installed according installation manual which can be found within this document.

Please consult latest Declaration of Performance on our website:



www.klimaoprema.com/fdsd/dop

For more information about certificates, visit our website:

www.klimaoprema.com/fdsd

- E** - Integrity
- I** - Insulation
- 120/90/60** - Classification time in minutes
- S** - Smoke leakage
- Vew** - Damper installed in vertical wall
- i↔o** - Fire performance criteria are met on both sides



TECHNICAL DATA

Smoke control damper casing is manufactured from galvanized steel sheet, but on demand can be produced out of:

- Galvanized steel and powder coated
- Stainless steel (AISI 304/316)
- Stainless steel and powder coated (AISI 304/316)



1					2
	SERIAL NUMBER	29560500100001			
	PRODUCTION DATE	28.10.2020			3
4	TYPE:	FDSD – 500X300 – M230			
5	DIMENSION:	500x300x350	LOCATION:		
6	ACT. MECHANISM:	M230	IP PROTECTION:		9
7	NOMINAL VOLTAGE:	AC 230	FREE SPACE (dm2):	10,81	10
8	SIGNALISATION	Yes			
15			EN 12101 – 8:2011		11
16	1396		CLASS C EN1751		12
			Multicompartment		
			Smoke control damper		
			EI90 (Vew i < – > o)S 1500 C 10000 AAmulti		13
	PRODUCT MUST BE INSTALLED BY INSTRUCTIONS SUPPLIED BY MANUFACTURER				
					14
	29560500100001				

- [PRODUCT OVERVIEW](#)
- [DIMENSIONS](#)
- [INSTALLATIONS](#)
- [ACTUATORS](#)
- [COMMUNICATIONS MODULES](#)
- [REPLACEMENTS](#)
- [MAINTENANCE AND OPERATION](#)



PRODUCT OVERVIEW

SMOKE CONTROL DAMPERS

Rating plate

- 1 - Company logo
- 2 - Serial number
- 3 - Production date
- 4 - Type
- 5 - Dimension of the smoke control damper
- 6 - Mechanism type
- 7 - Nominal voltage
- 8 - Signalisation (end contacts)
- 9 - IP protection
- 10 - Free space
- 11 - Number of the European standard and year of its publication
- 12 - Classification according to EN 1751
- 13 - Classification according to EN 13501-4
- 14 - Barcode
- 15 - CE conformity marking symbol
- 16 - Identification number of the notified product certification body

Product specifications

Nominal sizes FDSD	200x200 - 1500x800 [mm]
Casing length	350 mm
Temperature range	-20 °C ... 50 °C
Volume flow rate range	up to 20.700 m ³ /h
Differential pressure ranges	up to 2.000 Pa
Casing air leakage	Class C, EN 1751
Closed blade air leakage	Class 3, EN 1751
Upstream velocity	< 12 m/s
EC conformity	EN13501-4, EN1366-10, EN12101-8, EN1751, CPR no.3/2011
Declaration of performance	DoP No. 1716/2020_EN

Ordering key

(1) Damper type (2) Dimension (3) Mechanism type

FDSD - 400x300 - M230

(1) **FDSD** (3) **M24** - electric actuator AC 24 V
M230 - electric actuator AC/DC 230 V

(2) Damper dimensions
B(W) x H [mm]

FDSD



- ▶ [PRODUCT OVERVIEW](#)
- ▶ [DIMENSIONS](#)
- ▶ [INSTALLATIONS](#)
- ▶ [ACTUATORS](#)
- ▶ [COMMUNICATIONS MODULES](#)
- ▶ [REPLACEMENTS](#)
- ▶ [MAINTENANCE AND OPERATION](#)

↑ DIMENSIONS

SMOKE CONTROL DAMPERS

Actuator	A [mm]	C [mm]	D [mm]	E [mm]
BEN (M)	25	200	90	120
BEE (M)	25	225	100	120

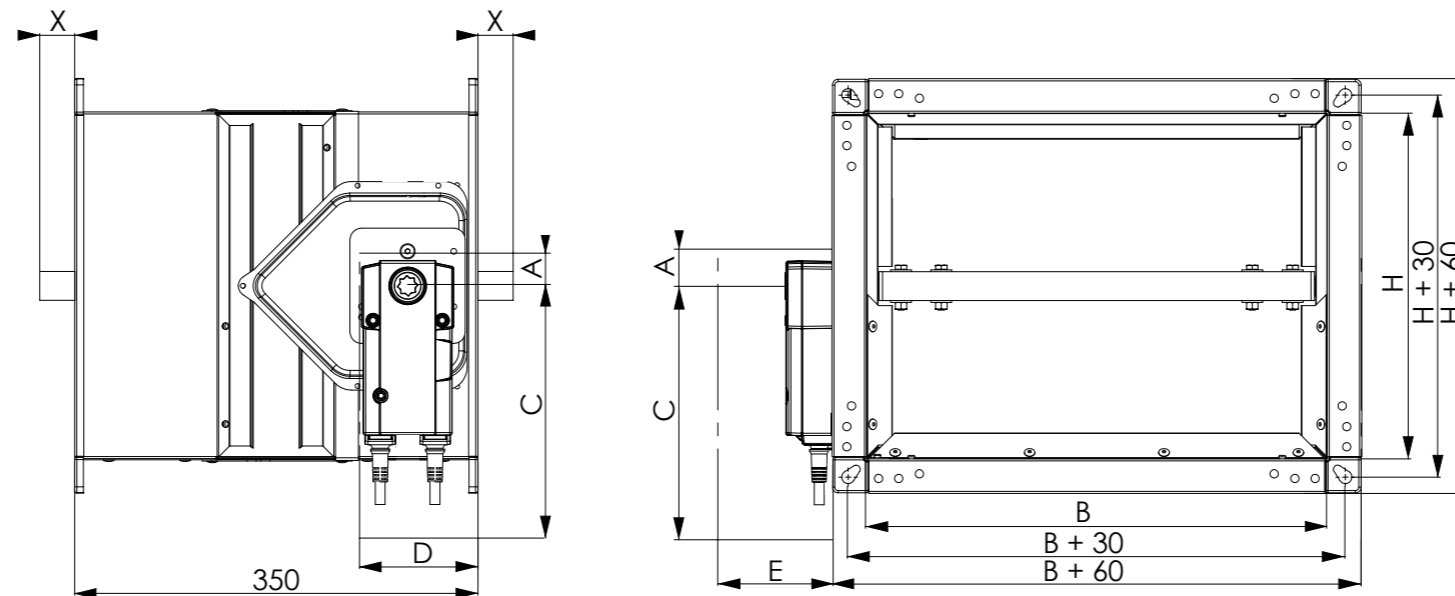

Length of damper blade outside of casing:

$$X = (H/2) - 175 \text{ [mm]}$$

		FDSD Weight [kg]																											
H/B	100	150	200	250	300	350	400	450	500	550	600	650	700	750	800	850	900	950	1000	1050	1100	1150	1200	1250	1300	1350	1400	1450	1500
200			6,8	7,5	8,2	8,9	9,7	10,4	11,1	11,8	12,6	14,0	14,7	15,5	16,2	16,2	16,9	17,6	18,3	19,1	19,8	20,5	21,3	22,0	22,7	23,4	24,2	24,9	25,6
250	6,2	6,9	7,5	8,3	9,1	9,9	10,7	11,6	12,4	13,2	14,0	15,6	16,5	17,3	18,1	18,2	19,0	19,8	20,7	21,5	22,3	23,2	24,0	24,8	25,6	26,5	27,3	28,1	29,0
300	6,9	7,6	8,2	9,1	10,0	10,9	11,8	12,7	13,6	14,5	15,4	17,3	18,2	19,1	20,0	20,2	21,1	22,1	23,0	23,9	24,9	25,8	27,5	28,4	29,3	30,3	31,2	32,1	33,0
350	7,6	8,2	8,9	9,9	10,9	11,9	12,9	13,9	14,9	15,9	16,9	18,9	19,9	20,9	22,0	22,2	23,3	24,3	25,3	26,4	27,4	28,4	30,2	31,2	32,3	33,3	34,3	35,3	36,4
400	8,2	8,9	9,7	10,7	11,8	12,9	14,0	15,1	16,2	17,3	18,3	20,5	21,6	22,8	23,9	25,0	26,2	27,3	28,4	29,5	30,7	31,8	32,9	34,1	35,2	36,3	37,4	38,6	39,7
450	8,9	9,6	10,4	11,6	12,7	13,9	15,1	16,3	17,4	18,6	19,8	22,1	23,4	24,6	25,8	27,1	28,3	29,5	30,7	32,0	33,2	34,4	35,7	36,9	38,1	39,3	40,6	41,8	43,0
500	9,6	10,3	11,1	12,4	13,6	14,9	16,2	17,4	18,7	20,0	21,2	23,8	25,1	26,4	27,8	29,1	30,4	31,7	33,1	34,4	35,7	37,1	38,4	39,7	41,0	42,4	43,7	45,0	46,5
550	10,2	11,0	11,8	13,2	14,5	15,9	17,3	18,6	20,0	21,3	22,7	25,4	26,8	28,3	29,7	31,1	32,5	34,0	35,4	36,8	38,3	39,7	41,1	42,5	44,0	45,5	46,9	48,4	49,8
600	10,9	11,7	12,6	14,0	15,4	16,9	18,3	19,8	21,2	22,7	24,1	27,0	28,6	30,1	31,6	33,1	34,7	36,2	37,7	39,3	40,8	42,3	43,8	45,5	47,0	48,5	50,1	51,6	53,1
650	11,9	11,9	14,0	15,6	17,3	18,9	20,5	22,1	23,8	25,4	27,0	28,7	30,3	31,9	33,5	35,2	36,8	38,4	40,1	41,7	43,3	45,1	46,7	48,3	49,9	51,6	53,2	54,8	56,4
700	11,9	12,9	14,7	16,5	18,2	19,9	21,6	23,4	25,1	26,8	28,6	30,3	32,0	33,7	35,5	37,2	38,9	40,7	42,4	44,2	46,0	47,7	49,4	51,1	52,9	54,6	56,3	58,0	59,8
750	12,9	12,9	15,5	17,3	19,1	20,9	22,8	24,6	26,4	28,3	30,1	31,9	33,7	35,6	37,4	39,2	41,1	42,9	44,8	46,7	48,5	50,3	52,1	54,0	55,8	57,6	59,4	61,3	63,1
800	13,9	13,9	16,2	18,1	20,0	22,0	23,9	25,8	27,8	29,7	31,6	33,5	35,5	37,4	39,3	41,3	43,2	45,2	47,2	49,1	51,0	52,9	54,9	56,8	58,7	60,6	62,6	64,5	66,4

BEN-24/230

BEE-24/230

- [PRODUCT OVERVIEW](#)
- [DIMENSIONS](#)
- [INSTALLATIONS](#)
- [ACTUATORS](#)
- [COMMUNICATIONS MODULES](#)
- [REPLACEMENTS](#)
- [MAINTENANCE AND OPERATION](#)

Pressure drop tables

Pressure drop values are described with the “Zeta” values for each size. The exact pressure drop in [Pa] is calculated using the following formula:

$$\Delta p \text{ [Pa]} = \zeta * v^2 * 0,6$$

where ζ is Zeta value from the tables below, v is airflow velocity in [m/s]



SMOKE CONTROL DAMPERS

ZETA VALUES FDSD

H/B	200	250	300	350	400	450	500	550	600	650	700	750	800	850	900	950	1000	1050	1100	1150	1200	1250	1300	1350	1400	1450	1500
200	11,64	9,56	7,48	6,91	6,33	5,71	5,09	5,06	5,04	4,75	4,46	4,45	4,44	4,42	4,39	4,11	3,84	3,83	3,81	3,80	3,79	3,74	3,69	3,69	3,69	3,67	3,66
250	8,58	7,11	5,65	5,20	4,76	4,29	3,82	3,80	3,78	3,56	3,33	3,32	3,31	3,29	3,27	3,07	2,86	2,85	2,84	2,83	2,83	2,80	2,78	2,78	2,78	2,77	2,76
300	5,51	4,67	3,83	3,50	3,18	2,86	2,55	2,54	2,53	2,36	2,20	2,19	2,18	2,17	2,15	2,02	1,89	1,88	1,86	1,86	1,86	1,86	1,86	1,86	1,86	1,86	1,86
350	4,47	3,78	3,10	2,84	2,58	2,32	2,07	2,05	2,03	1,91	1,78	1,77	1,76	1,75	1,75	1,64	1,53	1,52	1,52	1,51	1,51	1,51	1,51	1,51	1,51	1,51	1,51
400	3,42	2,89	2,37	2,17	1,98	1,78	1,59	1,56	1,53	1,45	1,36	1,35	1,34	1,34	1,34	1,26	1,17	1,17	1,17	1,16	1,15	1,15	1,15	1,15	1,15	1,15	1,15
450	2,91	2,47	2,02	1,85	1,67	1,50	1,33	1,31	1,30	1,23	1,15	1,15	1,14	1,14	1,14	1,07	1,00	1,00	1,00	0,99	0,97	0,97	0,97	0,97	0,97	0,97	0,97
500	2,40	2,04	1,68	1,52	1,36	1,21	1,07	1,07	1,07	1,00	0,94	0,94	0,94	0,94	0,94	0,88	0,82	0,82	0,82	0,81	0,80	0,80	0,80	0,80	0,80	0,80	0,80
550	2,13	1,81	1,48	1,35	1,22	1,09	0,97	0,95	0,93	0,88	0,82	0,82	0,82	0,82	0,82	0,76	0,71	0,71	0,71	0,70	0,70	0,70	0,70	0,70	0,70	0,69	0,68
600	1,86	1,57	1,28	1,18	1,08	0,97	0,87	0,84	0,80	0,76	0,71	0,70	0,69	0,69	0,69	0,64	0,59	0,59	0,59	0,59	0,59	0,59	0,59	0,59	0,59	0,58	0,57
650			1,10	1,02	0,93	0,85	0,77	0,74	0,70	0,66	0,62	0,62	0,61	0,61	0,61	0,57	0,53	0,53	0,53	0,53	0,53	0,53	0,52	0,52	0,52	0,51	0,50
700			0,93	0,85	0,78	0,72	0,67	0,63	0,60	0,57	0,53	0,53	0,53	0,53	0,53	0,50	0,47	0,47	0,47	0,47	0,47	0,47	0,46	0,45	0,44	0,44	0,44
750				0,75	0,71	0,65	0,60	0,58	0,56	0,53	0,50	0,49	0,47	0,47	0,47	0,44	0,42	0,42	0,42	0,42	0,42	0,41	0,40	0,40	0,40	0,40	0,40
800					0,63	0,58	0,54	0,53	0,52	0,49	0,46	0,44	0,41	0,41	0,41	0,39	0,36	0,36	0,36	0,36	0,36	0,36	0,35	0,35	0,35	0,35	0,35



- ▼ [PRODUCT OVERVIEW](#)
- ▼ [DIMENSIONS](#)
- ▼ [INSTALLATIONS](#)
- ▼ [ACTUATORS](#)
- ▼ [COMMUNICATIONS MODULES](#)
- ▼ [REPLACEMENTS](#)
- ▼ [MAINTENANCE AND OPERATION](#)

SMOKE CONTROL DAMPERS

INSTALLATION

FDSD smoke control damper is always tested in standardized support frames in accordance with EN 1366-2: 2015. The results obtained are valid for all similar support frames which have a thickness and / or density and / or fire resistance similar or greater than the one of the tests.

The duct connected to the smoke control damper must be supported or hung in such a way that the damper does not carry its weight. The damper must not support any part of the surrounding construction or wall which could cause damage and consequent damper failure. The damper driving mechanism can be placed on either side of the wall, however it needs to be placed so as to ensure easy access during inspection.

The smoke control damper must be installed into a fire partition structure in such a way that the damper blade in its closed position is located inside this structure.

The gap in the installation opening between the smoke control damper and the wall can be increased by up to 50% of the gap dimension, or decreased to the smallest dimension (B + 80 x H + 80)

- The installation must comply with the tests that were performed during certification
- FDSD smoke damper is connected to ducts made of calcium silicate boards and tested according to EN 1366-8. If it is connected to the ducts with lower fire resistivity, the smoke control damper will have fire resistivity of the duct.
- Avoid any obstruction of the moving blade by the connected ducts
- The class of air-tightness is maintained in case the installation of the damper is made in accordance with the technical manual
- For indoor use only

All dampers have to be installed with the blade axis in a horizontal position. To help you find the suspension plane, a bendable fixing bracket is provided on the damper casing and the red tape is placed on the casing to mark the location of the wall limit

(distance from wall limit to the end of smoke control damper is 125 mm). Check the operation of the smoke control damper before commencing the installation!

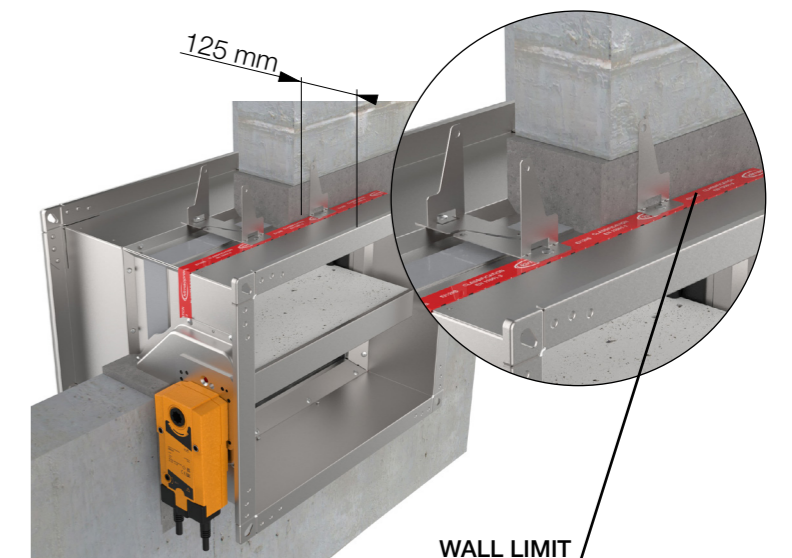
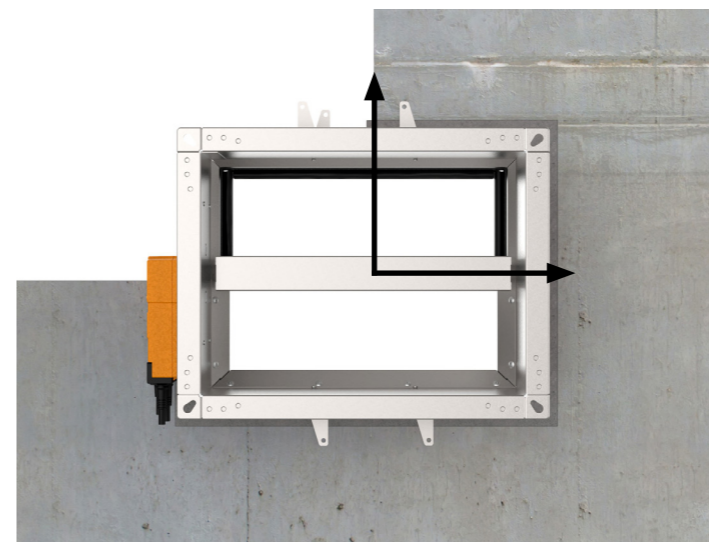

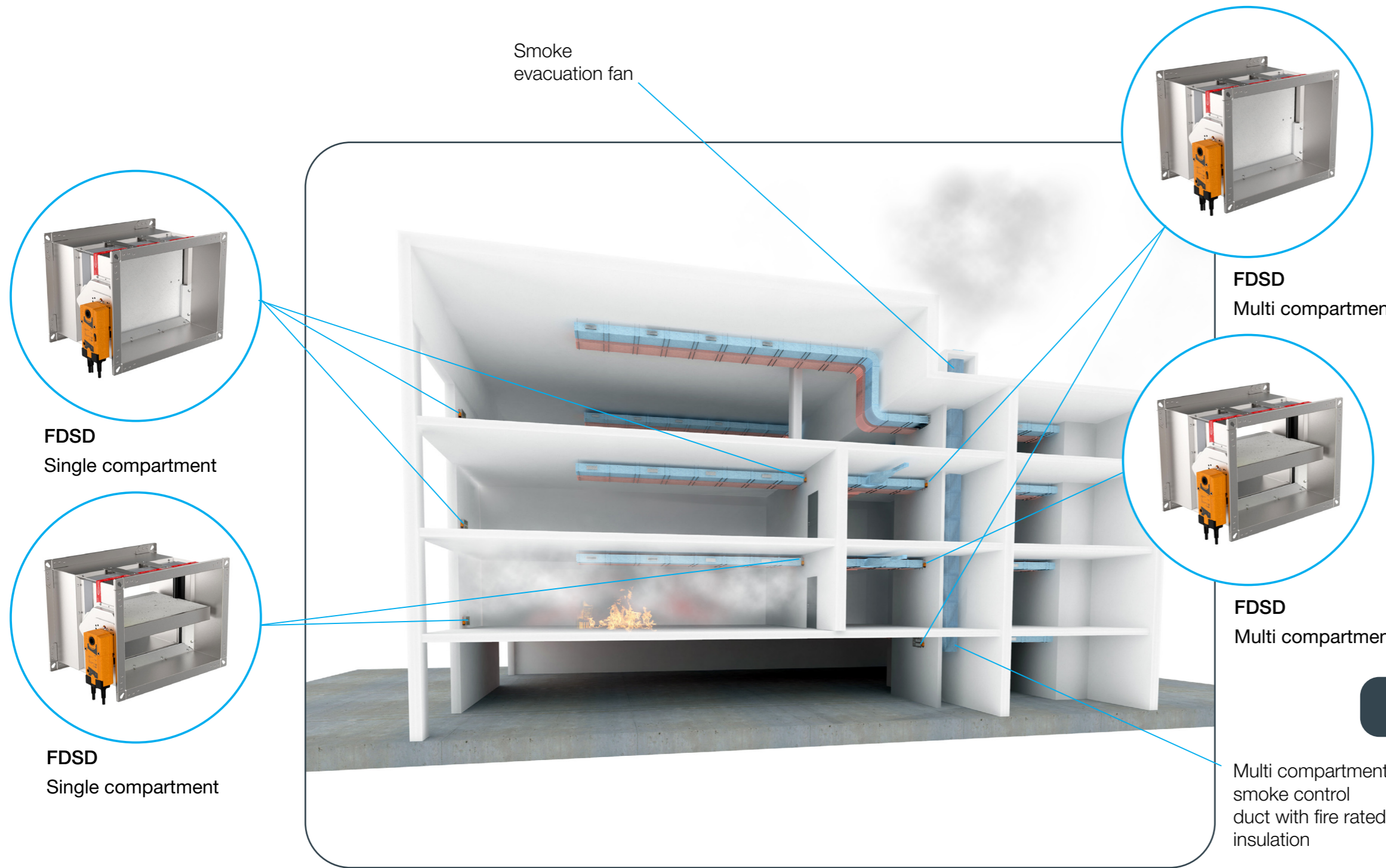

- ▼ [PRODUCT OVERVIEW](#)
- ▼ [DIMENSIONS](#)
- ▼ [INSTALLATIONS](#)
- ▼ [ACTUATORS](#)
- ▼ [COMMUNICATIONS MODULES](#)
- ▼ [REPLACEMENTS](#)
- ▼ [MAINTENANCE AND OPERATION](#)





SMOKE CONTROL DAMPERS

Multi compartment smoke control dampers

EN 12101-8: Smoke control dampers, which are fire resisting, for use in multi compartment areas, which may be associated with multi or single compartment smoke control ductwork and/or may be installed in a fire compartment structure.

Single compartment smoke control dampers

EN 12101-8: Smoke control dampers for use in single compartment areas, which may be associated with single compartment smoke control ductwork and/or may be installed in an external wall or roof.

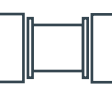
Range	Installation	Supporting construction	Type of installation	Wall thickness	Supporting construction details	Classification	Max. underpressure	Max. overpressure	Details
	Installation in wall	Rigid wall	Gypsum plaster / Mortar	≥ 100 mm	Aerated concrete, Reinforced concrete, Gypsum blocks etc (≥ 450 kg/m³)	EI 90 (vev - i ↔ o) S 1500 C10000 AA multi	1500Pa	500Pa	▼  
FDSD	Installation in wall (duct-one side)	Rigid wall	Gypsum plaster / Mortar	≥ 100 mm	Aerated concrete, Reinforced concrete, Gypsum blocks etc (≥ 450 kg/m³)	EI 90 (vev - i ↔ o) S 1500 C10000 AA multi	1500Pa	500Pa	▼  
	Installation in wall (duct-both sides)	Rigid wall	Gypsum plaster / Mortar	≥ 100 mm	Aerated concrete, Reinforced concrete, Gypsum blocks etc (≥ 450 kg/m³)	EI 90 (vev - i ↔ o) S 1500 C10000 AA multi	1500Pa	500Pa	▼  

Check for more information about certificate installations in the declaration of performance:

www.klimaoprema.com/fdsd/dop

 Aerated concrete (≥ 450 kg/m³) or reinforced concrete (≥ 2200 kg/m³) wall, more than 100 mm thick

 Gypsum plaster, mortar sealing or mortar and cover boards

 Multi-compartment (one side), mortar sealing

 Multi-compartment (both side), mortar sealing

Support for installation with mortar

In the smoke control damper installations with mortar/gypsum plaster, it is necessary to use wooden supports to prevent the casing from deforming while mortar/gypsum plaster is getting hardened. Before filling the gap between wall and smoke control damper, close the damper blade and install the wooden supports as seen in the picture below.

Place the wooden support as close as possible to the smoke control damper blade!

Accessories

Accessories are not intended for connection to a duct!

1 Safety grill - safety grille and extension piece are assembled at the factory to form a unit and exclusively on the operation side of the damper. The free cross sectional area of the cover grille is approx. 70%.

It is not possible to install a safety grille on the damper casing without a extension piece!

2 Extension piece on operation side - length 350 mm.

3 Communication module bracket



SMOKE CONTROL DAMPERS

Ordering key

(1) Type (2) Accessories (3) Dimension

FD-A - SG1 - 800x600

(1) FD-A - accessories for FDSD

(2) SG1 - Safety grill on operation side
EXT1 - Extension piece on operation side

(3) BxH nominal size of the rectangular damper

Rigid wall installation (gypsum plaster / mortar sealing)

Rigid wall (aerated concrete, reinforced concrete, gypsum blocks, etc.) with minimum density of 450 kg/m³ and minimum thickness of 100 mm. Installation material: mortar or gypsum plaster.



INSTALLATION

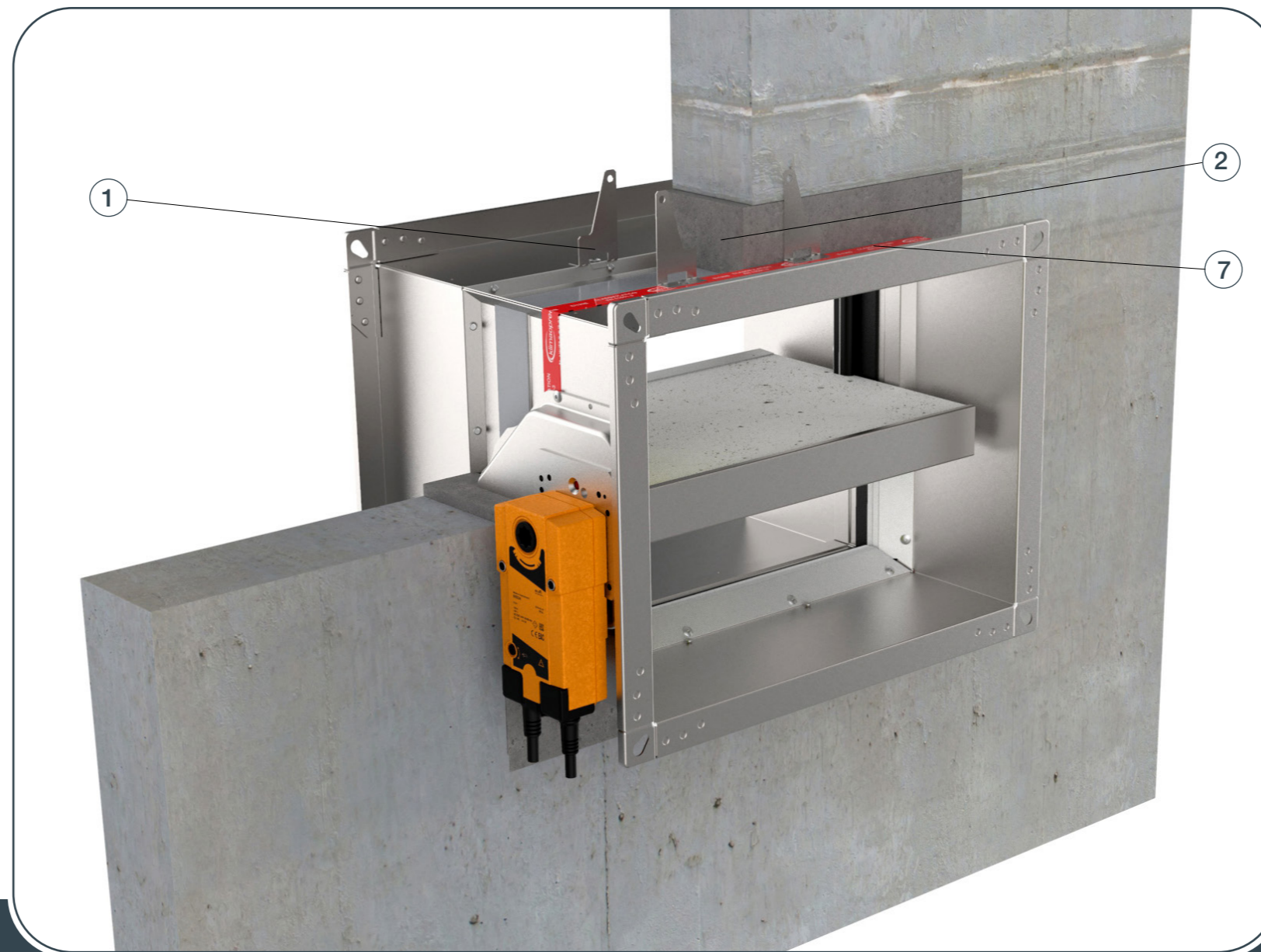

- ▼ [PRODUCT OVERVIEW](#)
- ▼ [DIMENSIONS](#)
- ▼ [INSTALLATIONS](#)
- ▼ [ACTUATORS](#)
- ▼ [COMMUNICATIONS MODULES](#)
- ▼ [REPLACEMENTS](#)
- ▼ [MAINTENANCE AND OPERATION](#)

SMOKE CONTROL DAMPERS

1. Recommended wall opening for the damper installation is B (H) + 80 mm or more (up to 50% more). Insert damper into wall to the wall limit mark **(7)** on the damper and bend the fixing bracket **(1)** 90°.

Damper blade must be closed during the installation!

2. Fix the damper to the wall with the screws. Bracket screw hole is 6 mm in diameter.

3. Fill the space between the damper and the wall with mortar or gypsum plaster **(2)**.

* Build the support for installation according to the drawing, [see page 9](#).

Test the operation of the damper blade!

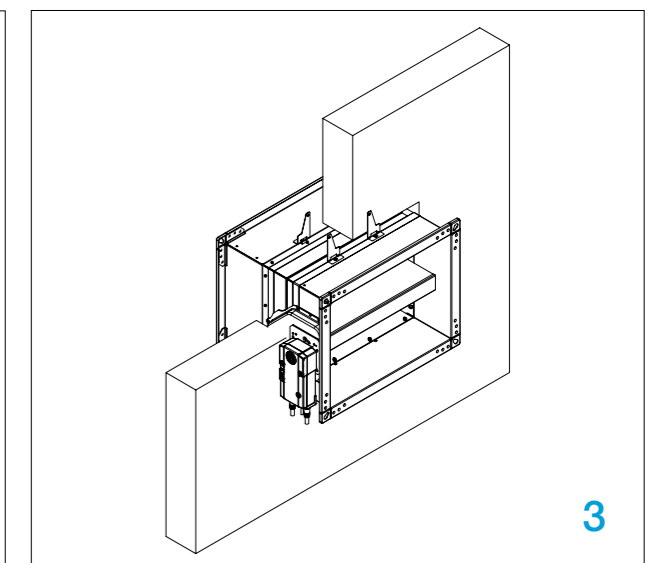
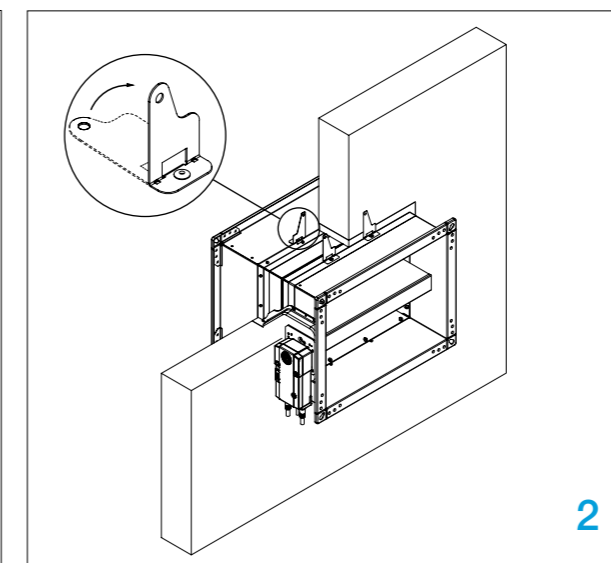
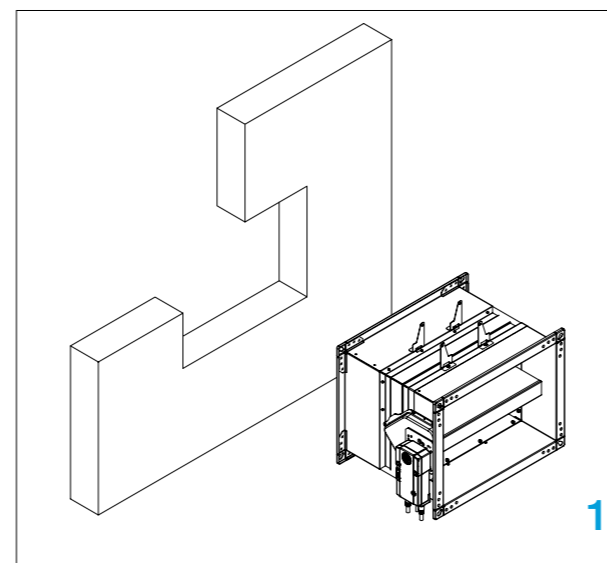

Rigid wall installation (gypsum plaster / mortar sealing)

Duct from one side

Rigid wall (aerated concrete, reinforced concrete, gypsum blocks, etc.) with minimum density of 450 kg/m³ and minimum thickness of 100 mm. Installation material: mortar or gypsum plaster.

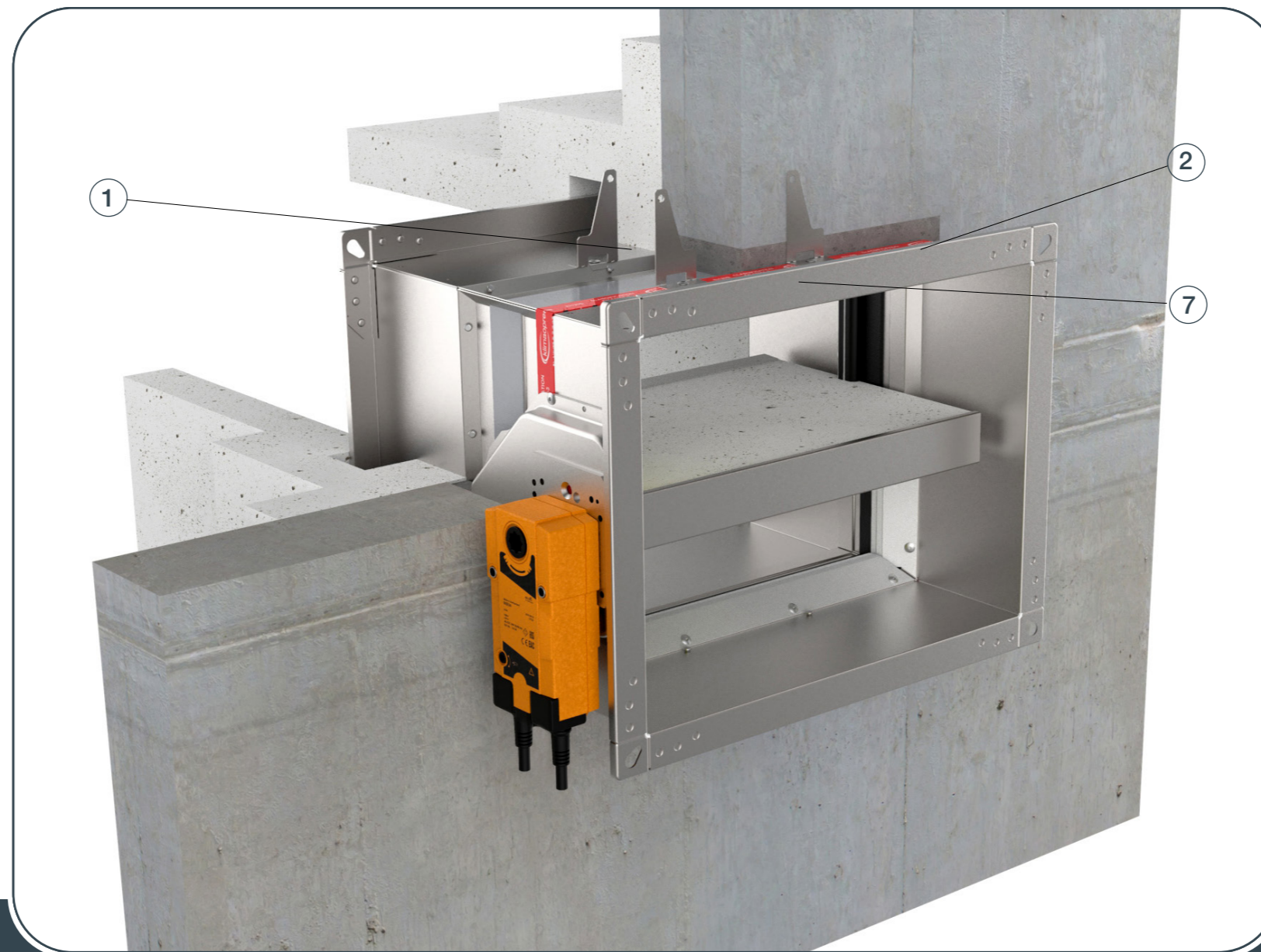

- ▼ [PRODUCT OVERVIEW](#)
- ▼ [DIMENSIONS](#)
- ▼ [INSTALLATIONS](#)
- ▼ [ACTUATORS](#)
- ▼ [COMMUNICATIONS MODULES](#)
- ▼ [REPLACEMENTS](#)
- ▼ [MAINTENANCE AND OPERATION](#)



INSTALLATION

SMOKE CONTROL DAMPERS

1. Recommended wall opening for the damper installation is B (H) + 80 mm or more (up to 50% more). Insert damper into wall to the wall limit mark **(7)** on the damper and bend the fixing bracket **(1)** 90°.

Damper blade must be closed during the installation!

2. Fix the damper to the wall with the screws. Bracket screw hole is 6 mm in diameter.

3. Fill the space between the damper and the wall with mortar or gypsum plaster **(2)**.

* Build the support for installation according to the drawing, [see page 9](#).

* Build a channel support according to the drawing, [see page 13](#).

Test the operation of the damper blade!

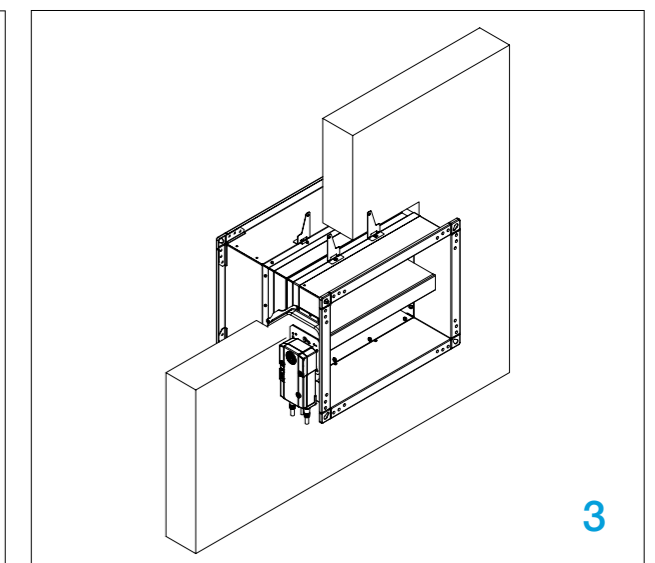
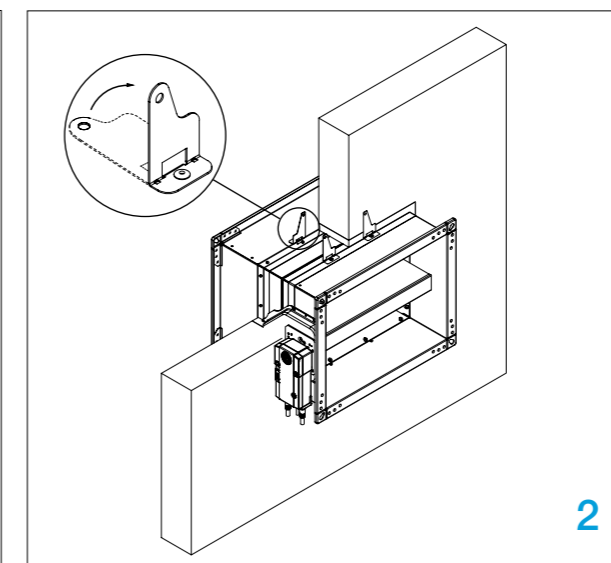
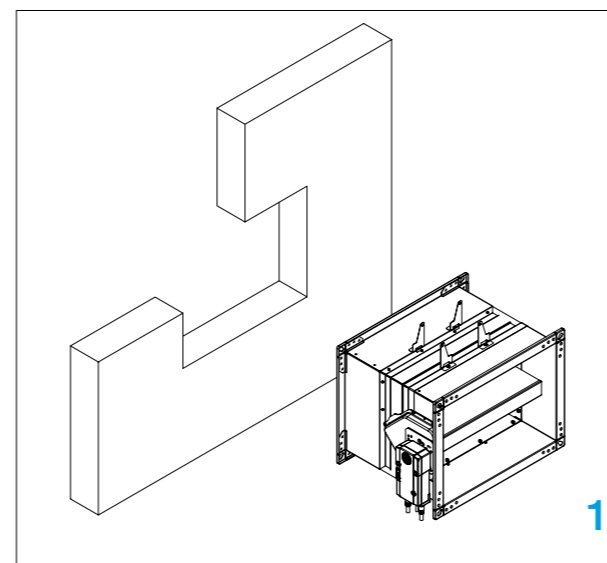

Rigid wall installation (gypsum plaster / mortar sealing)

Duct from both sides

Rigid wall (aerated concrete, reinforced concrete, gypsum blocks, etc.) with minimum density of 450 kg/m³ and minimum thickness of 100 mm. Installation material: mortar or gypsum plaster.

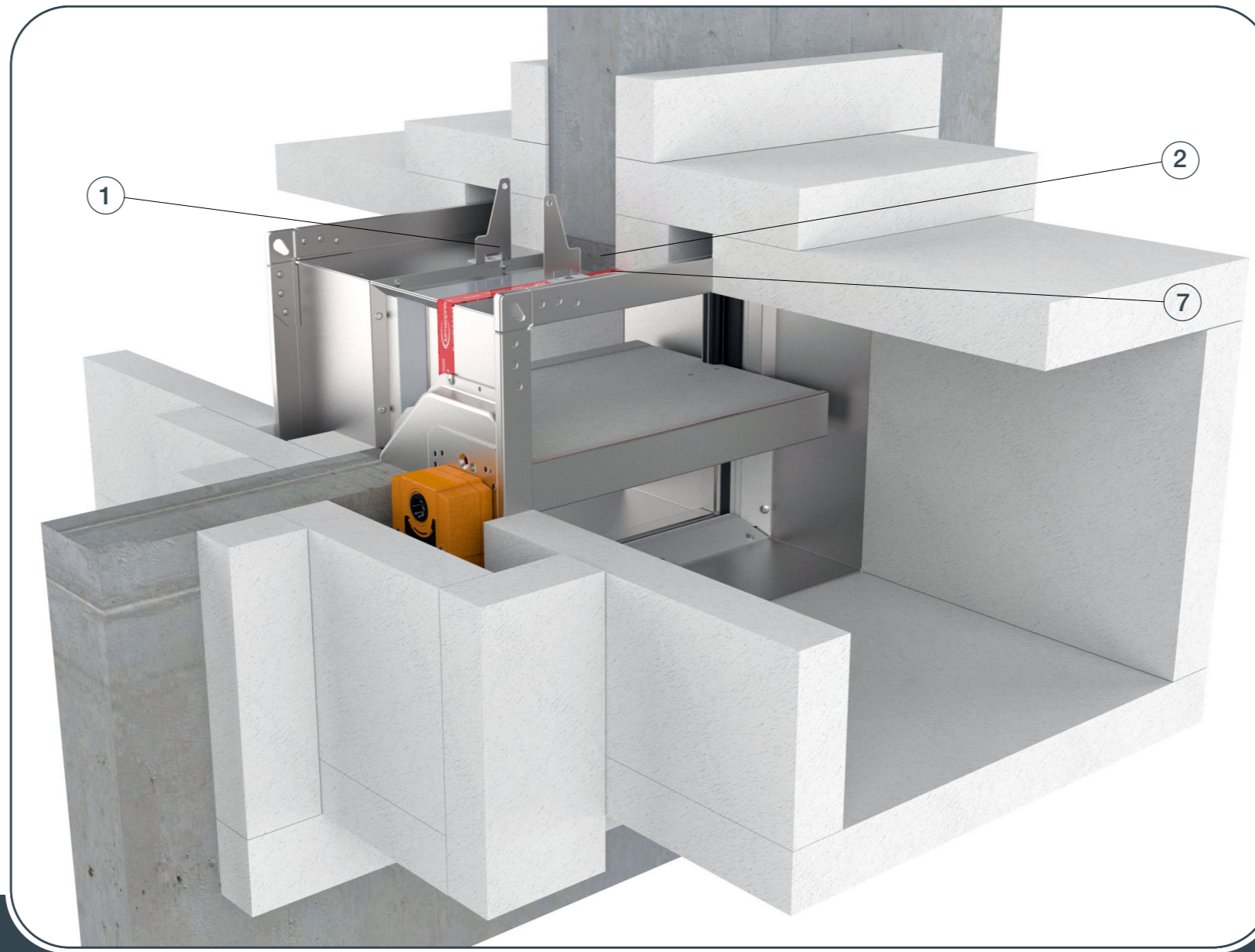

- ▼ [PRODUCT OVERVIEW](#)
- ▼ [DIMENSIONS](#)
- ▼ [INSTALLATIONS](#)
- ▼ [ACTUATORS](#)
- ▼ [COMMUNICATIONS MODULES](#)
- ▼ [REPLACEMENTS](#)
- ▼ [MAINTENANCE AND OPERATION](#)

 INSTALLATION

SMOKE CONTROL DAMPERS

1. Recommended wall opening for the damper installation is B (H) + 80 mm or more (up to 50% more). Insert damper into wall to the wall limit mark **(7)** on the damper and bend the fixing bracket **(1)** 90°.

Damper blade must be closed during the installation!

2. Fix the damper to the wall with the screws. Bracket screw hole is 6 mm in diameter.

3. Fill the space between the damper and the wall with mortar or gypsum plaster **(2)**.

* Build the support for installation according to the drawing, [see page 9](#).

* Build a channel support according to the drawing, [see page 13](#).

Test the operation of the damper blade!

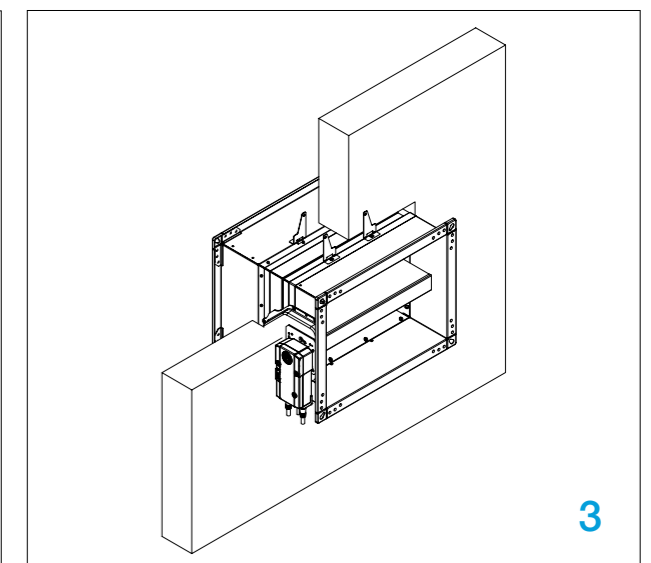
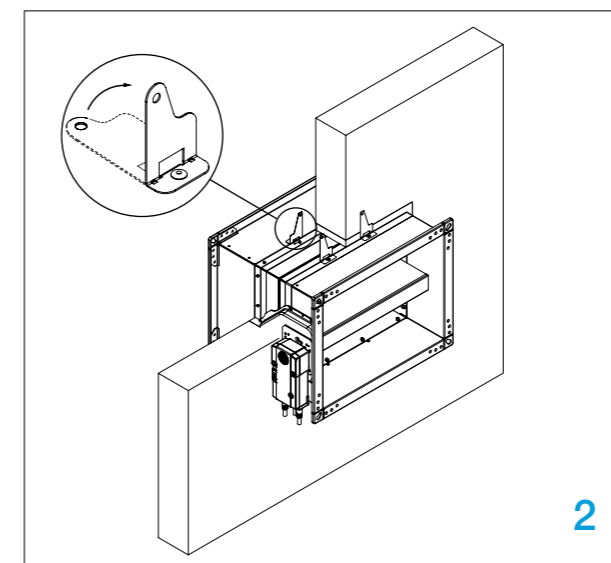
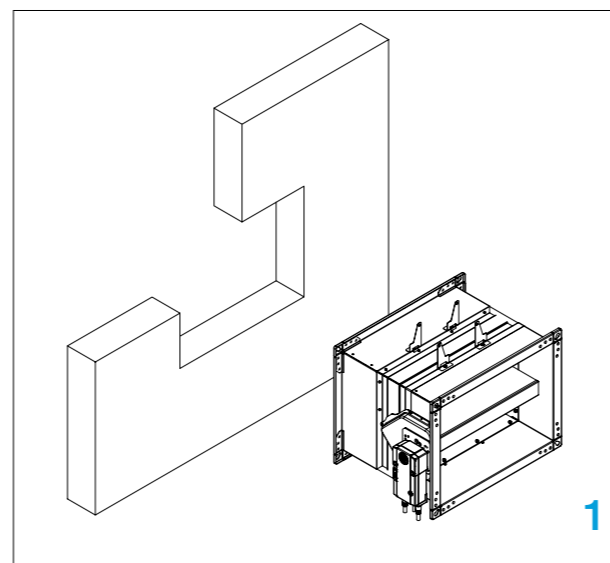

Rigid wall installation

Duct from one side

- 1 - FDSD smoke damper
- 2 - Gypsum mortar / mortar
- 3 - Solid wall
- 4 - Promatec L500 50mm strip
- 5 - Promatec L500 50mm strip
- 6 - Promatec L500 50mm board
- 7 - Fire-resistant smoke extract duct
- 8 - Dry wall screw / staple

WARNING: All duct connection surfaces are glued together with Promat K84 and fixed with screws and/or staples!

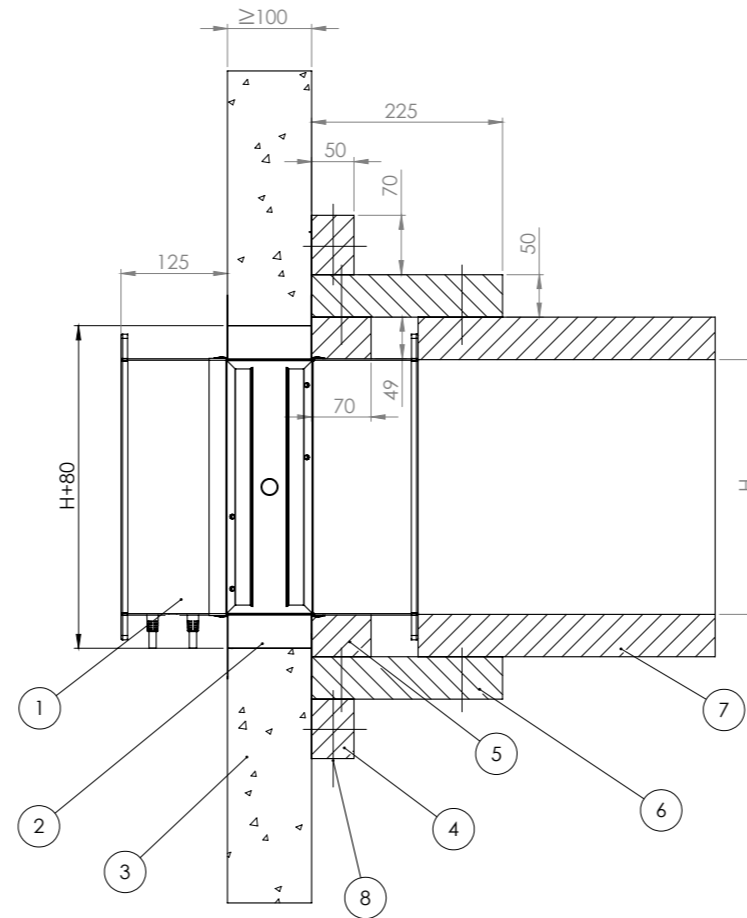

Rigid wall installation

Duct from both sides

- 1 - FDSD smoke damper
- 2 - Gypsum mortar / mortar
- 3 - Solid wall
- 4 - Promatec L500 50mm strip
- 5 - Promatec L500 50mm strip
- 6 - Promatec L500 50mm board
- 7 - Fire-resistant smoke extract duct
- 8 - Dry wall screw / staple
- 9 - Promatec L500 50mm board

WARNING: All duct connection surfaces are glued together with Promat K84 and fixed with screws and/or staples!

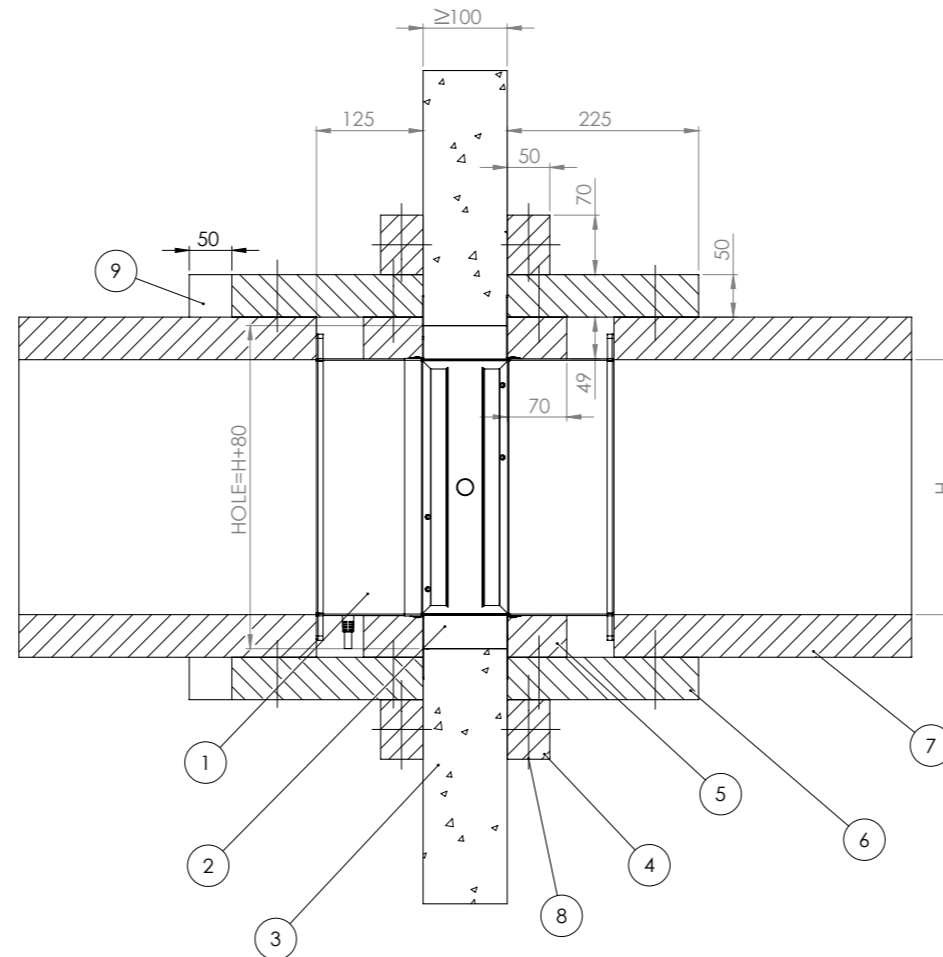

- ▶ [PRODUCT OVERVIEW](#)
- ▶ [DIMENSIONS](#)
- ▶ [INSTALLATIONS](#)
- ▶ [ACTUATORS](#)
- ▶ [COMMUNICATIONS MODULES](#)
- ▶ [REPLACEMENTS](#)
- ▶ [MAINTENANCE AND OPERATION](#)

SMOKE CONTROL DAMPERS

ELECTRIC ACTUATOR

BEN 24 V, BEN 230 V, BEE 24 V, BEE 230 V

Damper is delivered in closed position. The actuator features 2-wire open/close control. Actuator is overload proof and can remain energized at the end stops. Safety position lock enables the actuator to hold the damper in the defined safety position in case of fire.



- ▼ [PRODUCT OVERVIEW](#)
- ▼ [DIMENSIONS](#)
- ▼ [INSTALLATIONS](#)
- ▼ [ACTUATORS](#)
- ▼ [COMMUNICATIONS MODULES](#)
- ▼ [REPLACEMENTS](#)
- ▼ [MAINTENANCE AND OPERATION](#)



Technical specifications

Type of Belimo actuator	BEN 24 V	BEN 230 V	BEE 24 V	BEE 230 V
Torque	15 Nm	15 Nm	25 Nm	25 Nm
Nominal voltage / power	voltage	AC/DC 24V 50/60 Hz	AC 230 V 50/60 Hz	AC/DC 24V 50/60 Hz
	operation	3 W	4 W	2,5 W
	rest position	0,1 W	0,4 W	0,1 W
Angle of Rotation	95°	95°	95°	95°
Running time	< 30 s / 90°		< 60 s / 90°	
Mechanical interface	Form fit 12x12 mm			
Control	Open-close, modulating			

Two microswitches with fixed settings are installed in the actuator for indicating the damper end positions. It should be noted in this application, however that the contacts can no longer be used in the milliampere range after larger currents have been applied to them, even if this has taken place only once. The position of the damper blade can be read off on a mechanical position indication. Manual operation is possible with the hand crank that is provided with the actuator.

Wiring diagram

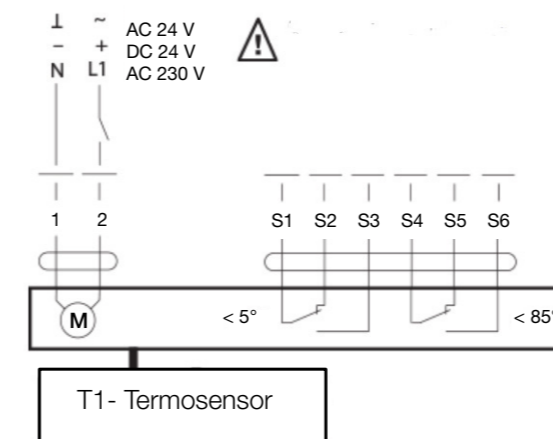

- 1 negative (direct-current) or neutral (alternating current)
- 2 positive (direct-current) or faze (alternating current)
- S1 common micro switch closed damper
- S2 normally closed micro switch closed damper
- S3 normally open micro switch closed damper
- S4 common micro switch open damper
- S5 normally closed micro switch open damper
- S6 normally open micro switch open damper
- T1 termosensor

COMMUNICATION MODULES POWERLINE

- 230 VAC Powerline communication on field side
- Topology: Free
- Max. distance between master and slave: 1200 m
- Display of damper position (incl. angle**)
- Button on device for damper function check
- Relay outputs for enabling ventilation
- Optional control and monitoring via Modbus RTU (RS-485) or Modbus TCP/IP (Ethernet) BACnet MS/TP or BACnet IP
- Optional monitoring on external computer or on control cabinet touch screen (TCP/IP communication)
- USB interface and CDU software for simple configuration and diagnostics at on-site computer
- Event logging

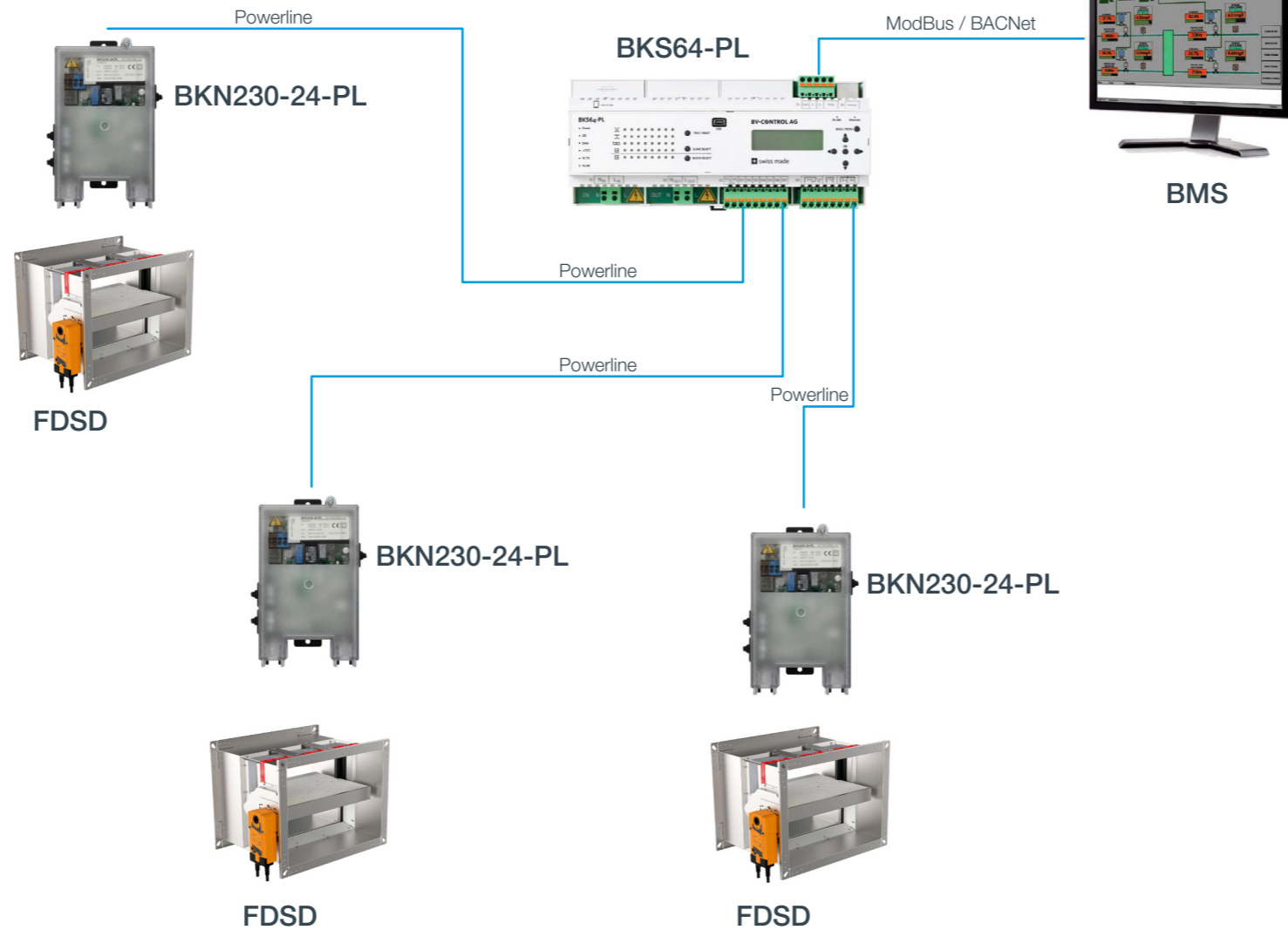

- ▼ [PRODUCT OVERVIEW](#)
- ▼ [DIMENSIONS](#)
- ▼ [INSTALLATIONS](#)
- ▼ [ACTUATORS](#)
- ▼ [COMMUNICATIONS MODULES](#)
- ▼ [REPLACEMENTS](#)
- ▼ [MAINTENANCE AND OPERATION](#)



COMMUNICATIONS MODULES

SMOKE CONTROL DAMPERS

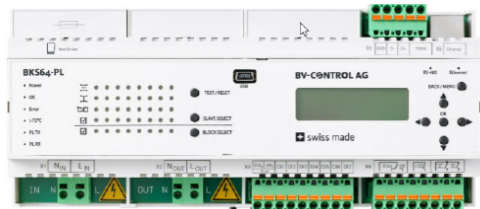

BKS64 - PL is a master for up to 64 BKN230-24-PL devices. It is a control and display module for motorized fire protection dampers or smoke extraction dampers. It communicates with the slaves directly via the 230 VAC power cable. The Powerline slaves (BKN230-24-PL) have a unique physical MAC address and can therefore be detected automatically irrespective of pre-addressing. Automatic or selective addressing, which is primarily for spatial location, can be carried out on the slave itself before installation or later during commissioning. The damper positions and any faults are displayed directly on the device. Dampers can be selected and tested with the pushbutton. The dampers can be opened and closed via potential-free contact or +24 VAC/DC external voltage. The master can also be controlled via MODBUS (TCP/IP and RTU) or BACnet (IP or MS/TP) and therefore can be considered as a Modbus/Powerline or BACnet/Powerline Gateway.

[Technical documentation BKS](#)

BKN230-24-PL is the link between the Powerline Master (e.g. BKS64-PL) and the motorized smoke control damper. It supplies a conventional spring return or a Belimo Top-Line “-ST” actuator and optionally an optical smoke detector with electrical energy. Communication with the master device takes place directly via the 230 VAC supply line (POWERLINE technology). The Powerline participants (BKN230-24-PL) have a unique physical MAC address and are therefore always recognized by the master, regardless of preaddressing or automatic addressing by the master.



- 230 VAC Powerline communication with dynamic signal adjustment and zero crossing detection
- Connection for a conventional or Belimo Topline actuator (auto recognition)

[Technical documentation BKN](#)

Power supply

Spring terminal for 230 VAC 2 x 2.5 mm² installation cable
 X1.1 Neutral conductor (N)
 X1.2 Phase conductor (L)
 Fuse protection:
 13 A, characteristic D if less than 32 x BKN230-24-PL
 16 A, characteristic D if 32 or more x BKN230-24-PL (slave fuse: 10A, slow-blow)

Powerline output

Spring terminal for 230 VAC installation cable
 X1.1 Neutral conductor (N)
 X1.2 Phase conductor (L)
 Cross section
 1.5 mm² if less than 32 x BKN230-24-PL
 2.5 mm² if 32 or more x BKN230-24-PL
 Connect optional shield to earth only at the master end.

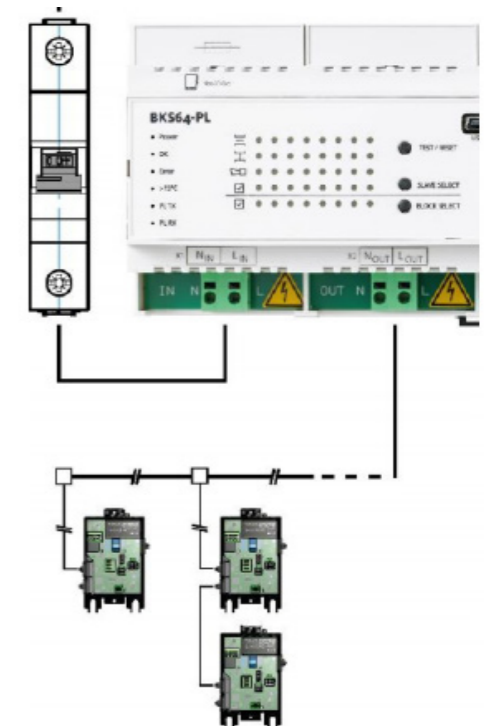

HOW TO ROTATE ELECTRIC ACTUATOR (Belimo)

200x200 to 1500x800

The blade must be closed before replacement the mechanism.

ERK Kit (FD-A-ERK)

- transition plate
- rectangular shaft
- 2x screws M6x30



[Video instructions](#)



- ▶ [PRODUCT OVERVIEW](#)
- ▶ [DIMENSIONS](#)
- ▶ [INSTALLATIONS](#)
- ▶ [ACTUATORS](#)
- ▶ [COMMUNICATIONS MODULES](#)
- ▶ [REPLACEMENTS](#)
- ▶ [MAINTENANCE AND OPERATION](#)

1) Locate the 2 hex screws, unscrew and remove actuator.

2) Remove FA transition plate and rectangular shaft.

3) Insert new transition plate and rectangular shaft from ERK kit.

NOTE

A Pay attention to the position of the indicator cut!
B Pay attention to the indicator cut, insert the ERK rectangular shaft that a smaller portion of the shaft enters ERK transition plate!

4) Fix the transition plate to the transition board and install the Belimo actuator.

Test the operation of the damper blade!

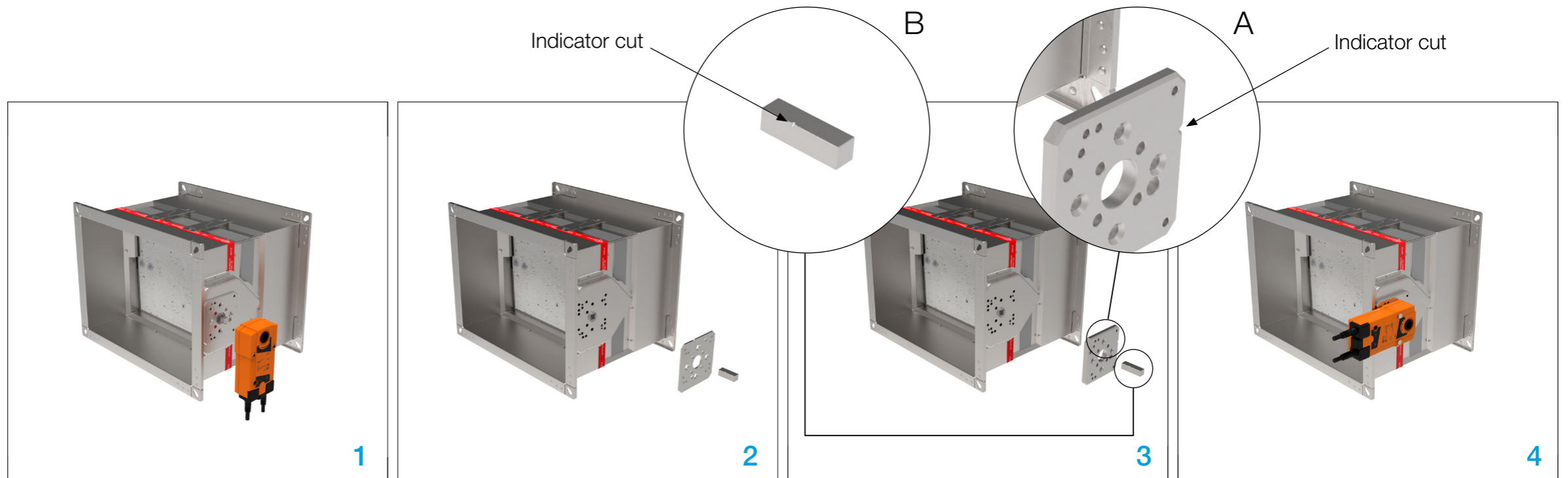



- ▼ [PRODUCT OVERVIEW](#)
- ▼ [DIMENSIONS](#)
- ▼ [INSTALLATIONS](#)
- ▼ [ACTUATORS](#)
- ▼ [COMMUNICATIONS MODULES](#)
- ▼ [REPLACEMENTS](#)
- ▼ [MAINTENANCE AND OPERATION](#)



TRANSPORT

After arrival, check the smoke control damper for transport damage and shortcomings. In case of any damage or shortcomings, immediately contact your supplier.

STORAGE

If the damper is not installed immediately:

- Remove any wrapping.
- Protect smoke control damper from dust and contamination.
- Do not expose the smoke control damper to the effects of weather - store damper in a dry place.
- Do not store the unit below -20 °C or above 50 °C.

Please properly dispose of packaging material!

MAINTENANCE AND OPERATION

Klimaoprema smoke control damper are designed with fully enclosed drive mechanism outside of the duct and as such do not require cleaning and regular maintenance. However, activation mechanism should be inspected for proper operation on regular basis.

- Provide at least one annual check of the damper
- After each intervention, provide a systematic cleaning of dust and especially the solenoid and its movable plate
- Check the if the electrical terminals are tightened
- Cleaning instruction: clean with a sponge, with water or a mild detergent
- Disinfection instruction: spray disinfectant (disinfectant may contain alcohol which is flammable, take precaution to avoid ignition)

It is not permitted to alter the dampers in any way nor perform any changes to their structure (except for the service procedures described in this manual) without the manufacturer's consent. Provide at least one annual check of the damper. The functional test must be carried out in compliance with the basic maintenance principles of the European norms EN 13306, EN 15423 and EN15650.

COMMISSIONING

- 1) Carefully unpack FSDS smoke control damper - be careful of sharp edges and do not use excessive force for unpacking
- 2) Inspect the smoke control damper - check the damper for damage
- 3) Installation of the smoke control damper - according to the installation instructions ([page 7.](#))
- 4) Before commissioning check the smoke control damper functions



SMOKE CONTROL DAMPERS

Projektiranje, proizvodnja i održavanje opreme za klimatizaciju, ventilaciju i čiste prostore.
Design, production and service of Ventilation, Air-Conditioning and Cleanroom equipment.

📍 Gradna 78A, 10430 Samobor, Croatia
☎ +385 (0)1 33 62 513
✉ info@klimaoprema.com
🌐 www.klimaoprema.com